

DATA

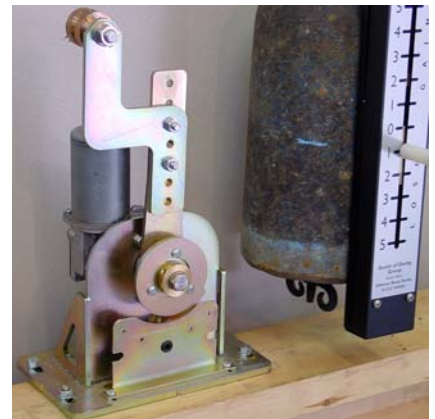
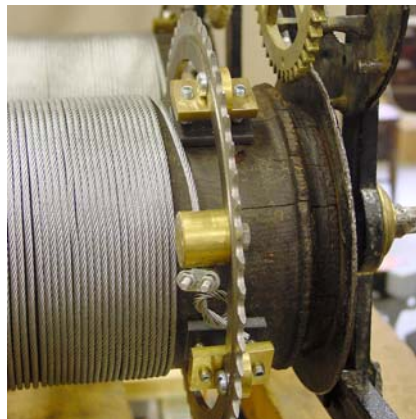
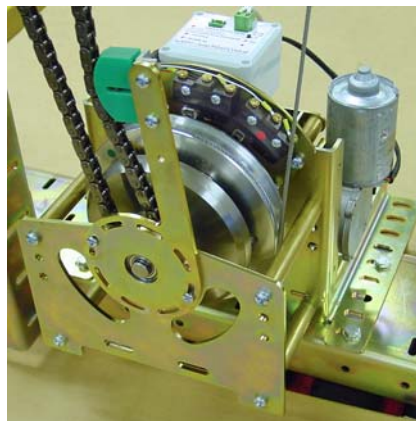
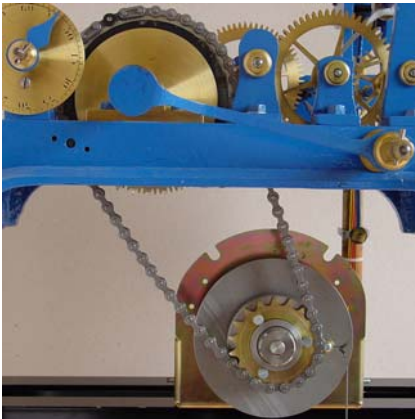

AUTOMATIC WINDING AND TIME CONTROL

TIME/MOVEMENT • RETAIL/URBAN • DESIGN/MANUFACTURING • INTERNATIONAL

Automatic winding

THE BENEFITS

- Eliminates the need for regular hand winding, giving time and cost savings
- Addresses the health and safety issues of access and heavy winding weights
- Reduces driving weight requirement
- Significantly reduces weightfall requirement
- 24 volt fail safe system
- Operates through power failures
- Conservation approved
- Patented

THE EXPERT SOLUTION

Our AW8 is the latest development of a product that has been manufactured for over 100 years. It has been designed to power a weight driven clock via the main barrel. This configuration most closely resembles the original weight power source of the clock. It also ensures regular speed of striking and chiming.

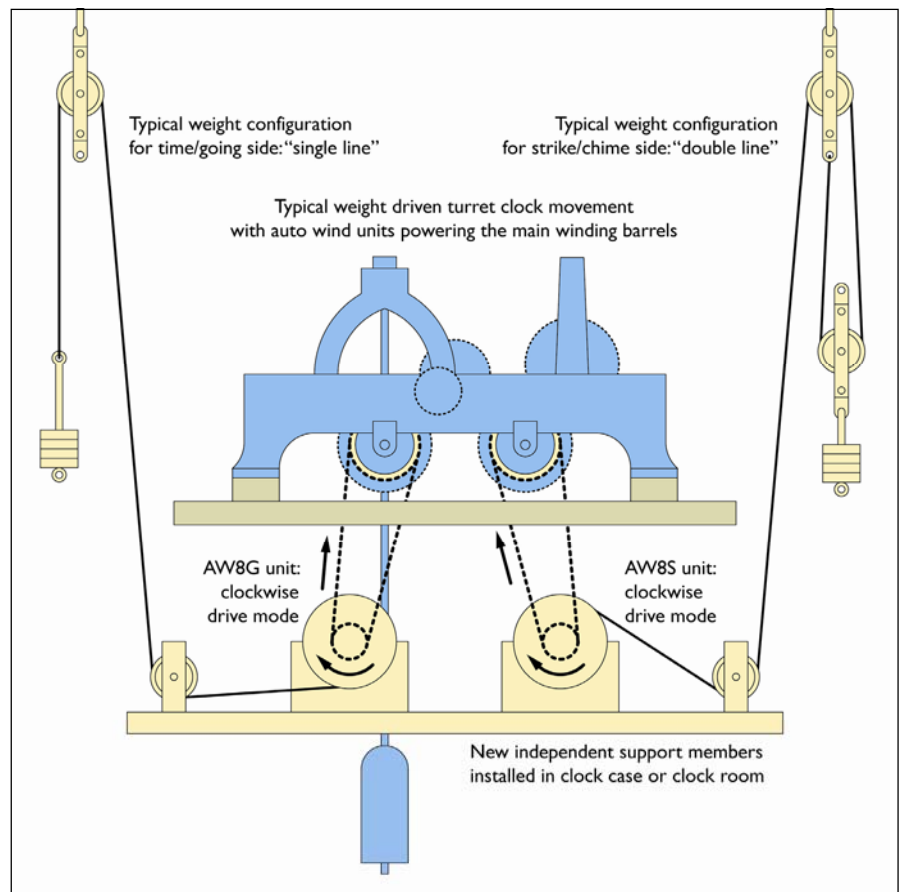

AW8 auto-wind units principal of operation. A separate unit is required for each clock "train".

Heritage: We work in consultation with clock conservation bodies such as the Council for the Care of Churches. Resulting from this partnership is a patented system which enables your clock to operate both the dials and the clock hammers with no requirement for manual winding.

Installation method: Our Auto-wind units are always installed on their own separate frames, and employ a special method of clamping the drive sprocket to the main winding barrel. The historical integrity of an existing church or tower clock is therefore never compromised. If required, the clock could be re-converted to its exact original manually wound configuration.

How the system works: Auto-wind units have their own weight line, weight and pulleys. In most cases their gearing enables them to apply sufficient power to the clock with less weight than when originally hand wound. Heavy and potentially hazardous weights can therefore be set aside and stored safely.

Auto-wind weights rise at frequent intervals, so the weight fall height they require is usually within the height of the clock room, and the requirement for a separate weight shaft is eliminated. However, in view of differing conservation requirements, it is possible to re-use existing weights and pulleys if necessary.

Continuous power: Auto-wind units provide uninterrupted weight power, even whilst they are in the process of winding. Safety switches guard against overwinding, and the system battery maintains power to the motor during power failures.

If the power supply is interrupted for a lengthy period, the weights will come to rest safely on the floor until power is restored, when the unit will re-wind.



A clock main barrel with AW8 sprocket fitted. Note the securing clamps and pads which require no holes to be drilled in the original barrel. The cable is tensioned to stabilise the sprocket and prevent slippage.

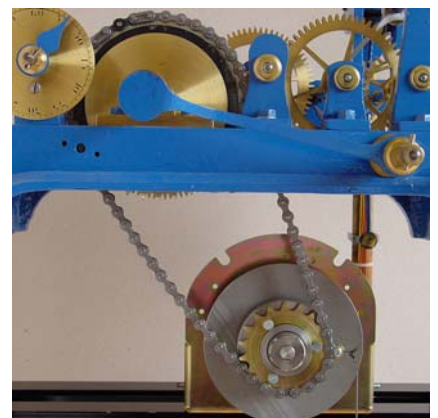

Pendulum Regulator

THE BENEFITS

- Automatic regulation using traditional techniques
- Operates through power failures
- Conservation approved
- Can also be fitted to a clock which is not automatically wound
- Patented

Auto-wound clocks continue to be affected by variations in temperature, humidity, and wind pressure on external hands. With our Regulator system you can enjoy the benefits of automatic timekeeping and still retain the historical integrity of your weight powered clock. These units can also be fitted to a clock that is not automatically wound.

The system compares clock time to “real” time, either quartz controlled or from a satellite GPS signal. It will, if required, move a small weight to make the pendulum of the clock run slightly faster or slower, enabling the clock to maintain accurate time.

The Pendulum Regulator is fully conservation approved. The main unit has special clamps which secure it to the pendulum adjacent to the weight.



Pendulum Arrester and Pendulum Regulator. These units may be installed separately or together as shown.

Pendulum Arrester

THE BENEFITS

- Automatic BST/GMT time change
- Can also be fitted to a clock which is not automatically wound

The arrester system interrupts the swing of the pendulum for 11 hours at the summer and 1 hour at the winter time changes. It can also be used for striking and chiming clocks which have night silencing, by stopping the clock for 23 hours or 13 hours.

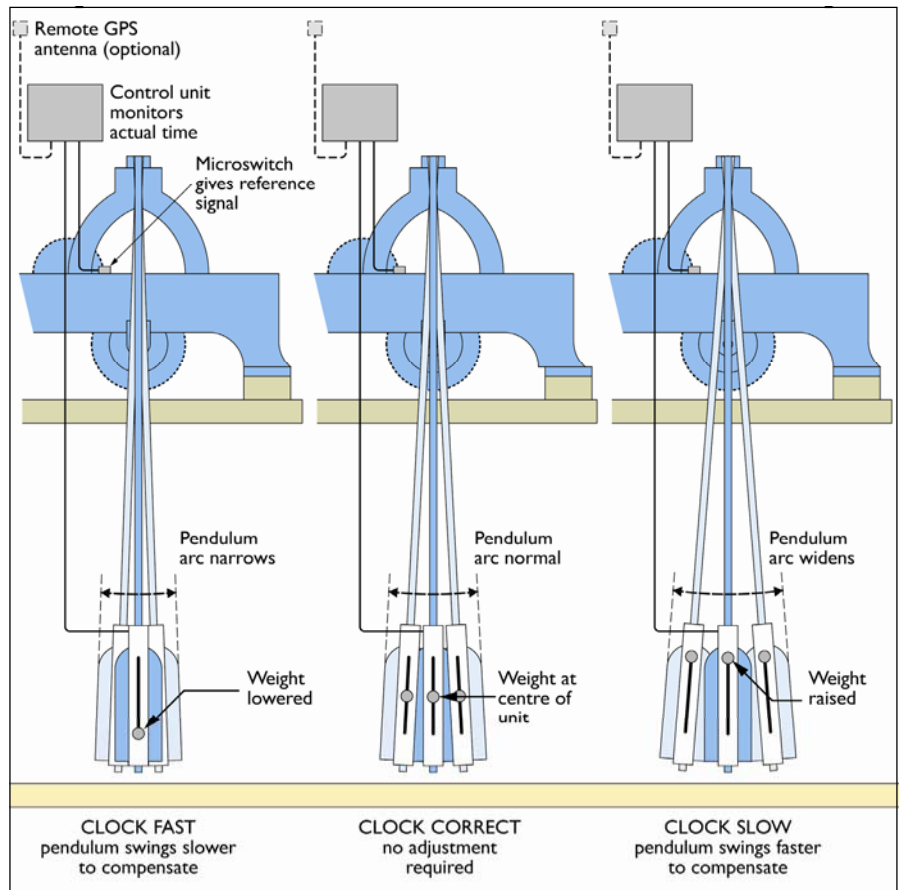

Pendulum Regulator operation closely resembles the traditional way in which clocks have been adjusted by raising or lowering the centre of gravity of the pendulum. This was sometimes done with coins such as Victorian pennies.

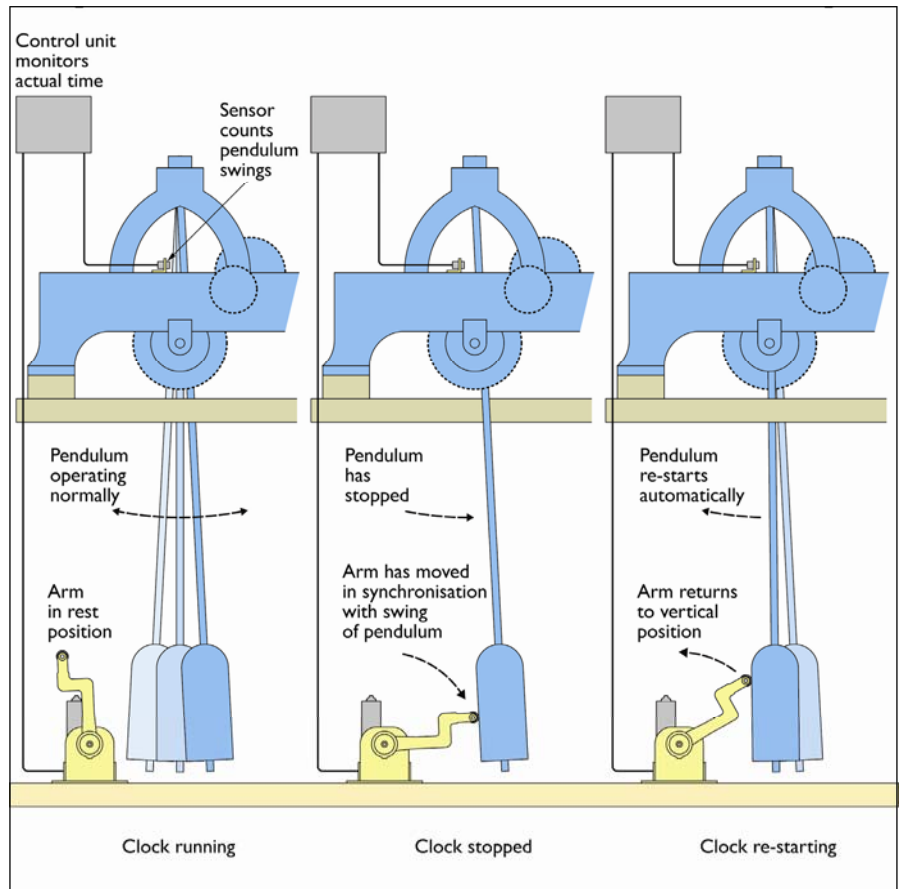

Pendulum Arrester operation. The control unit is programmed for 80 years from the date of installation, and upgradable in the event of future changeover date amendments.

Installation

- Fully trained engineers
- Timekeeping set-up equipment
- Full warranty

We provide a full installation service throughout the British Isles. Our clock engineers carry a comprehensive range of parts and tools to ensure that your clock installation is set up accurately and works reliably.

All new equipment is backed by a 12-month warranty against faulty workmanship and materials.

Please contact us for full details of our installation and warranty agreements.

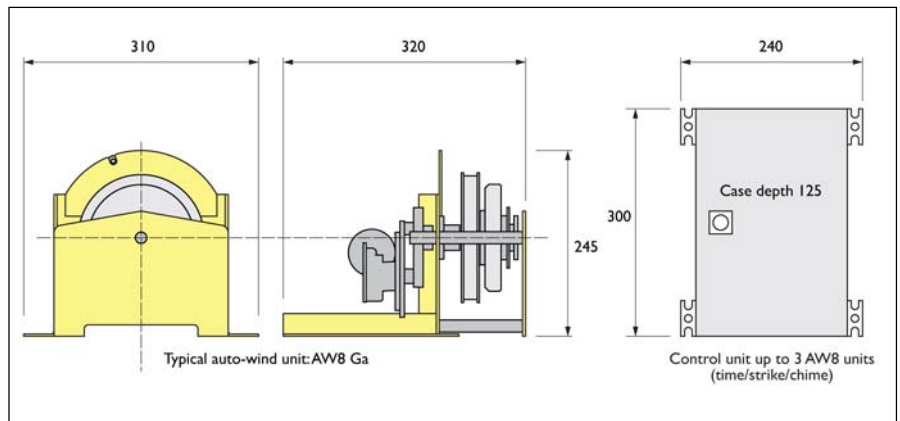

Smith of Derby Auto-wind Unit overall dimensions. There are 6 models in the range:

AW8 Ga (timekeeping) and AW8 Gb (timekeeping, heavy duty)

AW8 Sa (striking or chiming) and AW8 Sb (striking or chiming, heavy duty)

AW8 Ca (tune playing) and AW8 Cb (tune playing, heavy duty)

Due to variations in the design and operation of historic weight driven clocks, Smith of Derby may adapt the above models as required for an individual installation.

Power requirements: input: 220-240V/100-120V, 50/60Hz, single phase, maximum 3A. System operates at 24V DC

Maintenance

- Annual service visit
- Safety checks
- Free additional visits*
- Conservation advice
- Exchange parts

KEEPING YOUR HERITAGE INTACT

Even with full automatic winding and time-keeping, your historic clock mechanism will still require regular maintenance visits.

We operate a comprehensive clock servicing network, giving year-round cover including one scheduled annual maintenance visit. Exchange motors and weight lines, software upgrades, additional call-outs and overhaul/repair advice are also included, (all subject to certain conditions).

Please contact us for full details of our annual maintenance contract.

*Full terms and conditions available on request.

Patents

Smith of Derby Auto-wind units: UK patent 2290155 and patent applications 0517104.6 & 0426345.5

Smith of Derby Pendulum Regulator units: UK patent 2376090

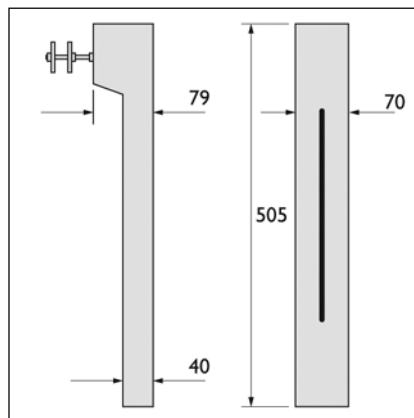

Pendulum Regulator overall dimensions.
Power requirements: input: 220-240V/100-120V, 50/60Hz, single phase, maximum 3A.
System operates at 12V DC

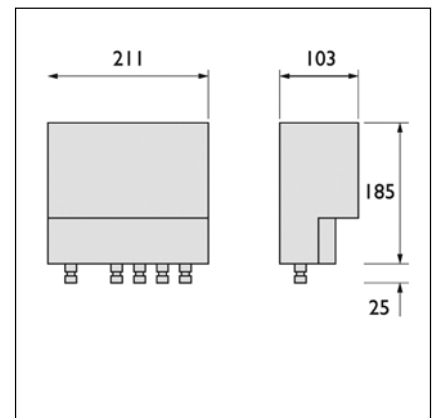

Control box overall dimensions for:
Pendulum Regulator.
Pendulum Stopper.
Each unit requires its own control box.

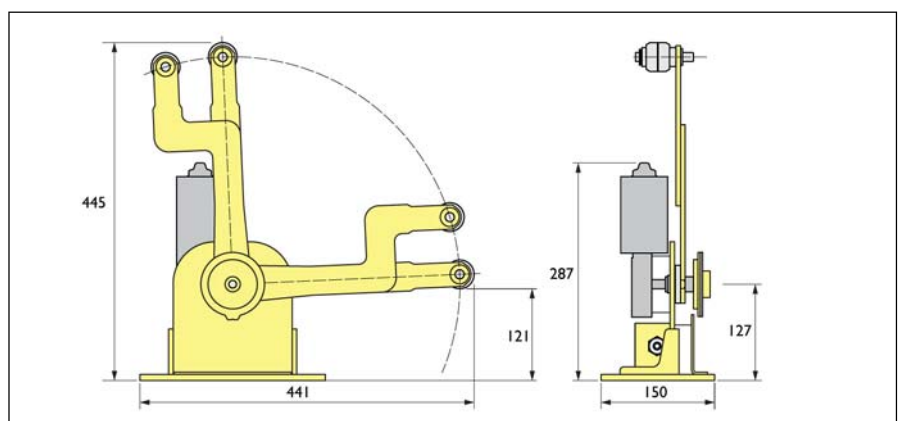

Pendulum Arrester overall dimensions.
Power requirements: input: 220-240V/100-120V, 50/60Hz, single phase, maximum 3A. System operates at 12V DC

COPYRIGHT: All designs © Smith of Derby Limited 2005. The design, price and specification of our products may vary without prior notice.

John Smith & Sons · Wm Potts & Sons · J B Joyce & Co · John Smith & Sons (Ireland) · These companies are divisions of
SMITH OF DERBY LTD, 112 Alfreton Road, Derby DE21 4AU United Kingdom
tel · +44 (0)1332 345569 fax · +44 (0)1332 290642 e-mail · sales@smithofderby.com web · www.smithofderby.com

