

## DC MASTER CLOCK - MC200

### GENERAL INFORMATION

The DC Master clock is designed to control up to four Smith of Derby 12v dc Slave Clocks. The unit is supplied for either a 100v-120v **or** 200v-240v power supply (specified when ordering) and a rechargeable 12v battery is fitted to run the Clock(s) during power outages. The Master Clock supplies timed pulses to the DC Slave Clocks causing them to move in half-minute increments.

A fully charged battery should continue to run the Master Clock and up to four clock motors for one or two days without power; if the battery voltage falls to 11.1volts the clocks will stop. When power is reinstated, and as soon as the battery has recovered to 12volts, the clocks will automatically advance to the correct time. The controls must not be touched during power outages as this will interfere with or cancel the auto correction system.

Daylight saving correction at the currently known BST/GMT times is automatic and the Master Clock will adjust the Slave Clocks to the new time. In countries where daylight saving adjustments are not made the changeover will be cancelled and this is indicated by an **o (off)** showing in the centre of the top line of the display. Normally this will show **(w)inter** or **(s)ummer**.

### BATTERY MAINTENANCE

The battery has a guaranteed life of one year and an expected life of five years (UK type climate). The battery type is Yuasa NP1.2-12. (12v-1.2Ah).

The battery should be checked every twelve months by turning off the power for an hour or two to establish that the clocks continue to operate. The battery voltage is indicated on the display and during the check, the voltage should not drop **significantly**; if it should fall quickly to 12 volts this would indicate a failing battery which should be replaced. Contact the maintenance department for help. A fully charged battery should read above 13 volts.

A very long power outage could cause the battery voltage to fall to a level where it may not recover, and at this point the display information would disappear. When power is resumed, the display will show **Battery Low** whilst the battery is charging and if it does not recover then the clocks will remain stopped.

## INSTALLATION

The Master Clock must be installed by competent personnel in order that guarantees are not invalidated. The unit is for internal use only and must not be installed where it will be subjected to great temperature variation or dampness, such as exposed walls, window openings etc. or direct sunlight.

The case has three mounting holes and should be fixed with three No 8 round head screws. The top-fixing hole is a **keyhole** and the screw should be fitted first to enable the unit to be correctly positioned. The two lower holes are accessed by removing the lower panel. Alternatively, the case can be clipped directly on to a DIN rail.

## ELECTRICAL CONNECTIONS AND INITIAL SETTINGS

### MASTER CLOCK

The unit must be connected to the power supply via a fused spur unit conforming to current electrical regulations and should be fused at 3 amps and correctly earthed/grounded.

### SLAVE CLOCKS

Connect each slave clock to the Master clock as shown in the wiring diagrams.

Alternative wiring methods are shown so that the best method can be used to suit the number of clocks and where they are located.

NB. It would be useful to make a note of which clock dial face is connected to each of the numbered outputs of the Master Clock. This allows any of the clocks to be run or stopped independently to correct a specific dial if for some reason this becomes necessary, it will be extremely useful- if not essential - where dial approach is difficult.

Corrector switch No:	Dial Identification
1	
2	
3	
4	

Normally all slave clocks will be supplied with the hands set to 12 o'clock. If a starting time different from this is necessary, the hands can be adjusted manually to a more suitable time during installation. See the clock movement instructions supplied separately.

1. Connect the power lead from the Master clock to a fused spur unit or standard power socket. Ensure a 3-amp fuse is fitted.
2. Move the Battery switch to ON. The Master Clock Display should now show the time and date.

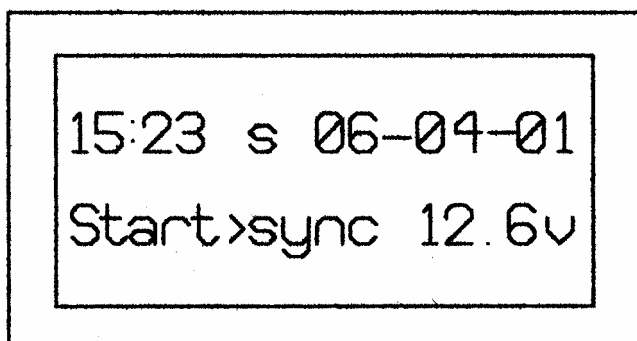

3. Turn on the external power switch.
4. Move the battery switch to **OFF** and check that the Display continues to show the time and date (this proves that the power charger is working). If the Display stays on, move the battery switch back to **ON**. If not, check the incoming power supply.
5. If the Display is showing an incorrect time or date then see the Display Setting instructions to correct this. Other information showing on the bottom line of the display should be **Start>Sync** and the voltage of the internal battery.
6. Turn the Security Switch to **Adjust** and press the **Start** button. Check that the clock hands on each clock face are moving; if they are not, check the wiring and that all corrector switches are turned **ON**.
7. When all clocks are moving, check that they all show the same time; if they do not, then match them up by using the corrector switches and the **Stop**, **Start**, and **Fast Forward** controls as required.

## ADJUSTING INDIVIDUAL CLOCK HANDS

Individual adjustment to any Slave Clock can be achieved by using the clock corrector switches provided in the lower compartment.

If it is necessary to advance a particular clock, then the corrector switches for the other clocks must be turned **OFF** whilst the clock which is incorrect is advanced. Likewise if it is necessary to stop one or any of the clocks in order to synchronise the clocks then switch off the corrector switches for those clocks whilst leaving the others to advance. Switch all corrector switches **ON** when all dials are synchronised.

## SETTING ALL THE CLOCK HANDS TO CORRECT TIME

This can be achieved by either a Manual or Automatic process.

### MANUAL SETTING

1. Turn the security key switch to the **Adjust** position.
2. Ideally, the hands should be set to a time in advance of real time and then stopped ready to simply press the **Start** button when that time is reached. However, if the time on the clock hands is some considerable time away from actual time then the hands can be set to advance at a rapid rate by pressing the **Fast Forward** button. (The clock hands will advance half a minute on the dial every 1.5 seconds). The indicator light on the front panel will show alternate red and green every time the clocks advance, therefore, counting either red or green flashes will show how many minutes have been advanced.
- NB. The clock hands will advance by approximately one hour every three minutes in fast forward mode.
3. Press the **Stop** button when the clock hands are in advance of real time. Check the time on the dials and then press the **Start** button when the Master Clock display shows the same time noted on the clock dials.
4. Turn the security key switch to **Locked** on completion.

### AUTOMATIC SETTING

This involves noting the time showing on the clock hands and then entering this time into the Master Clock which will then automatically adjust the clock hands to the correct time of day.

1. Turn the security key switch to the **Adjust** position.
2. Note the time showing on the clock hands.
3. Press the **Hands** button. The display changes to show **Hands at 00:00.0** and a flashing block showing over the hour digit to be adjusted.

The time noted from the clock hands can be entered into the Master Clock using either 12 or 24hour format e.g. **03:20** or **15:20**. For simplicity, 12-hour format is suggested.

4. Press the **Advance** button repeatedly until the correct hour is displayed.
5. Press the **Next** button. The flashing block moves over to the minute digit. Now press the **Advance** button repeatedly until the correct minute is displayed.

Note. If a wrong time is inadvertently entered, then press **Next** a number of times until the display changes to **Start>sync** then go back to operation 3. above and start the time setting again.

6. Press the **Next** button. The flashing block moves over the half-minute digit. Press **Advance** to alter the **0** to **0.5**. This is only necessary if it is clear the hands are not pointing to a minute mark on the dial.
7. Press **Next**. The display changes to show real time and **Start>sync** on the lower line.
8. Press **Start** to begin the automatic setting of the hands to the correct time.

NB If the time entered for the clock hands is less than 30 minutes in front of real time, the hands will not advance and will instead, remain stationary until real time reaches the time on the clock hands. The Display will show **Waiting** on the bottom line.

1. Turn the Security Key switch to **Locked** on completion.

## SETTING THE DISPLAY TIME AND DATE

The top line of the Master Clock Display shows – from the left- the current time, then a letter to show whether the automatic daylight correction system is in **(s)ummer**, **(w)inter** or **(o)Off** mode and then the date **(day, month and year)**.

When setting the display, it is advisable to enter a time which is a couple of minutes in front of actual time. This will allow enough time to set all of the time and date digits.

Whilst setting the display, the clock hands will stop moving (if they were already moving) and the bottom line of the display will show **Manual Stop**. If the clock hands were showing the same time as the display time, the clock hands will automatically move to the new time set on the display. If not then the clock hands may have to be adjusted. See the section **Setting All The Clock Hands**.

Turn the Security key switch to the **Adjust** position.

1. Press the **Display** button. The display shows a flashing block over the hour digit. If the hours do not require adjustment, go straight to no. 3. To adjust the hours, go to no. 2.
2. Press the **Advance** button repeatedly to advance the hours until the correct hour digits are displayed.
3. Press **Next**. The flashing block moves over the minute digit. If the minutes do not require adjustment, go straight to no. 5. To adjust the minutes, go to no. 4.
4. Press the **Advance** button repeatedly to advance the minutes until the correct digits are displayed. (Remember to add a couple of minutes).
5. Press **Next**. The flashing block moves over the year digit. If the years do not require adjustment, go straight to no.7. To adjust the years, go to no.6.
6. Press the **Advance** button repeatedly to advance the years until the correct digits are displayed.

7. Press **Next**. The flashing block moves over the month digit. If the months do not require adjustment, go straight to no. 9. To adjust the months, go to no. 8.
8. Press the **Advance** button repeatedly to advance the months until the correct digits are displayed.
9. Press **Next**. The flashing block moves over the date digit. If this does not require adjustment, go straight to no. 11. To adjust the date, go to no. 10.
10. Press the **Advance** button repeatedly to advance the date until the correct digits are displayed.
11. The display should now show a time in advance of real time (by the couple of minutes added).  
**When real time reaches the time displayed** - Press the **Next** button. This starts the display timing. The display will show **Start>sync** on the bottom line.
12. Press **Start** to start the clock hands moving.
13. Turn the Key switch back to the **Lock** position.

## DESCRIPTION OF CONTROLS

### SECURITY SWITCH

When in the **Lock** the function push buttons will not operate, thereby preventing unauthorised adjustment of the Master Clock.

Insert the Security Key into the lock and turn the key to the **Adjust** position for access to the control buttons. Return to the **Lock** position after use.

### HANDS

This changes the display to show **Hands at 00:00.0** and allows the time showing on the clock hands to be set into the Master Clock to initiate an automatic correction of the clock hands.

### NEXT

This is used during set up or alteration of the display details and moves the adjustment function to the next digit on the display.

### ADVANCE

During alteration of display information, this button will increment the digit flashing on the display.

## DISPLAY

This button allows the time and date information on the display to be altered.

## START

This button will start the half-minute pulses to move the clock hands. The display will show **Start>sync** when the button is to be pressed. This is usually after making some adjustment to the display or clock hands.

Each half-minute the pulse indicator light will flash alternate red and green as the clock hands advance.

## STOP

This will stop the clock hands.

## FAST FORWARD

The clock hands will immediately advance half a minute on the dials every one and a half seconds. This allows the clock hands to be moved quickly to a new time if required.

## PULSE LENGTH

This is normally set during manufacture and should not be altered.

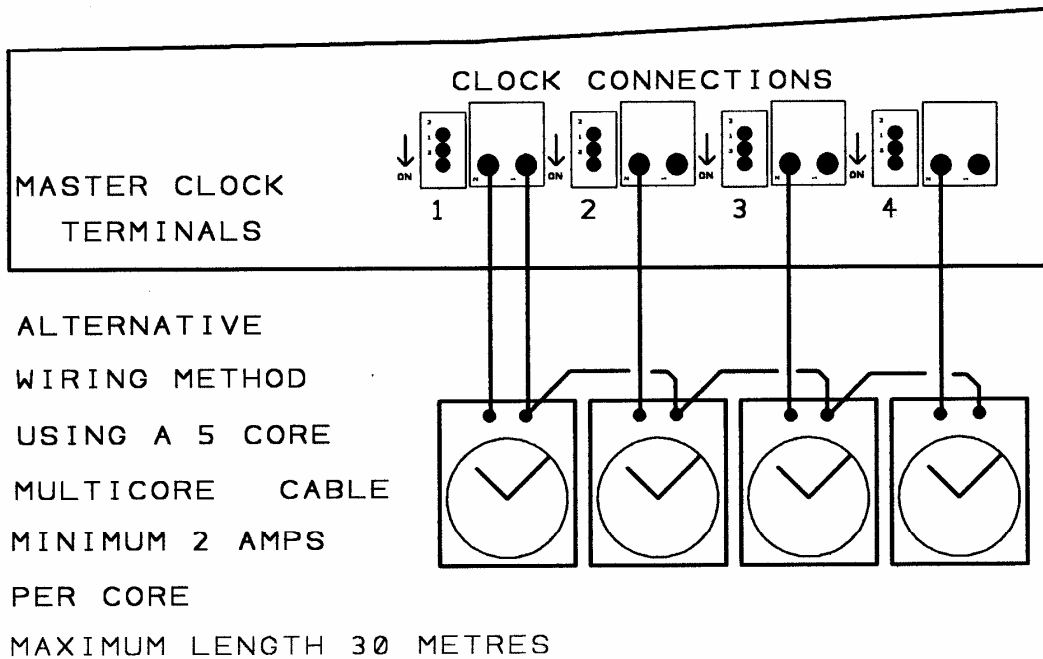
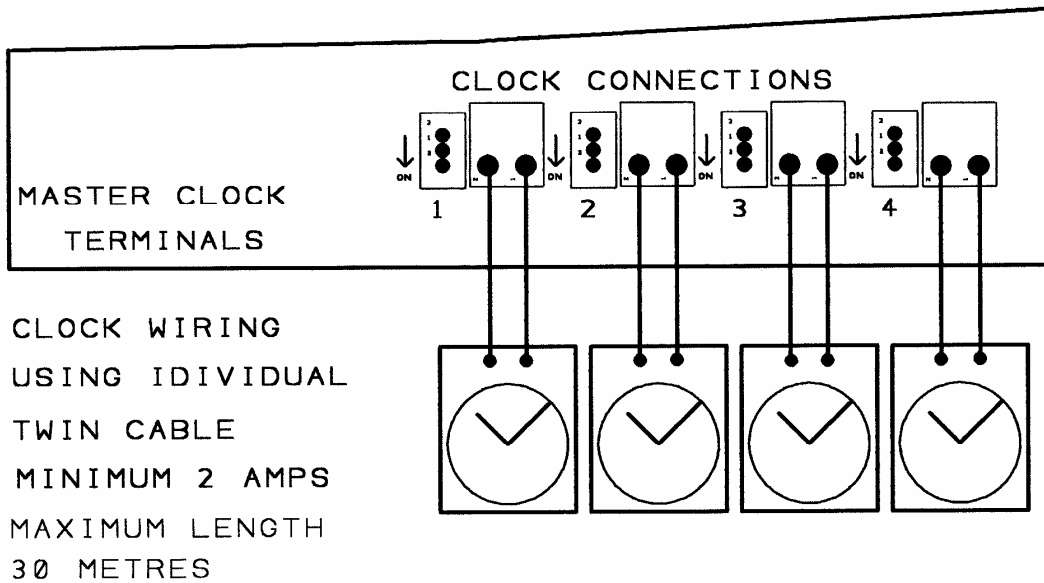

Project No.		Title	Date
		MASTER CLOCK WIRING DETAILS	MARCH 2001
Scale	Drawn	©Copyright Drawing. No part to be copied in any way without prior written consent <b>JOHN SMITH &amp; SONS</b> Midland Clock Works, 112 Alfreton Road, Derby DE21 4AU, England	Drawing No. DN235A
	BKL		

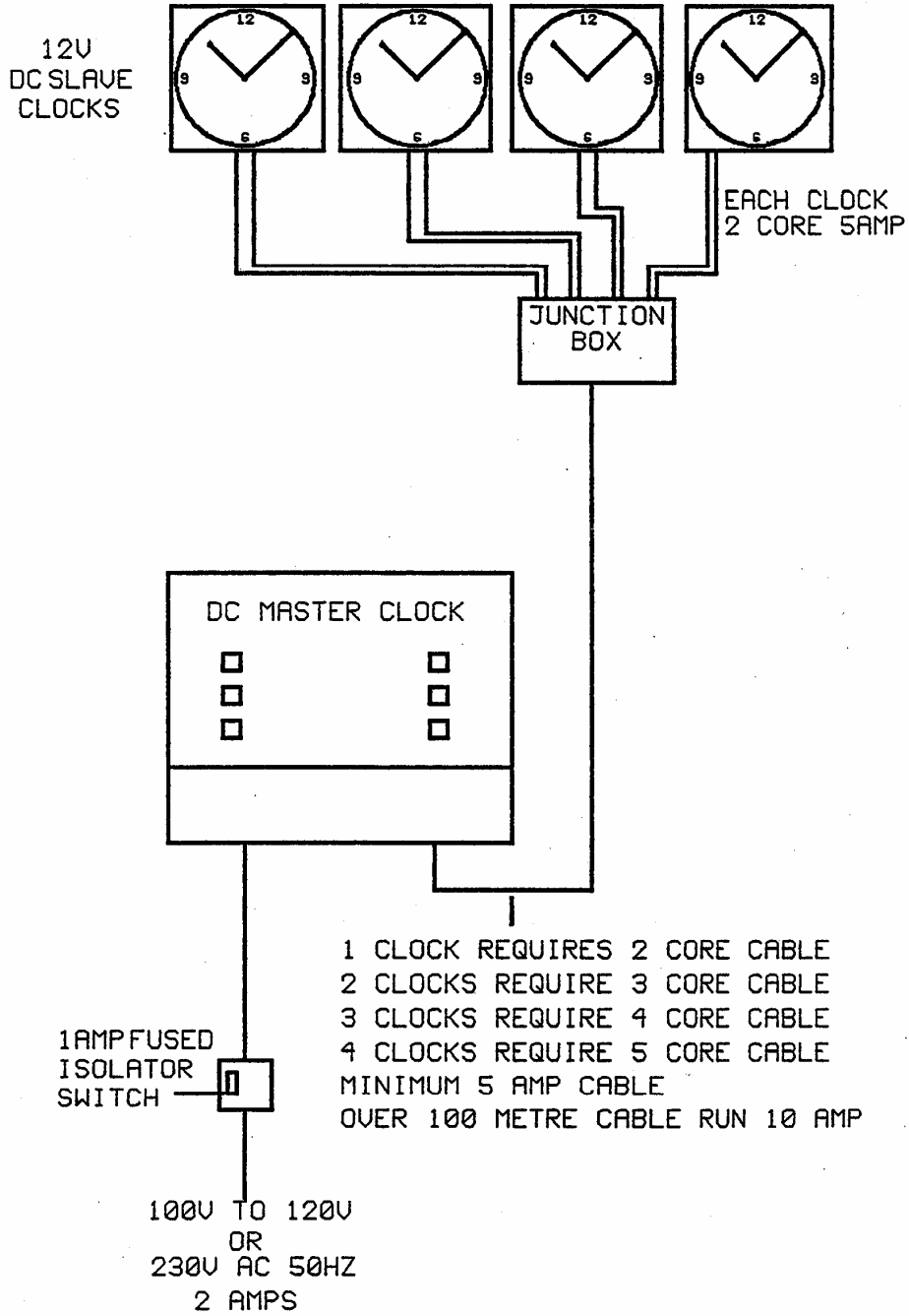

Project No. BKL	Title DC MASTER CLOCK AND SLAVE CLOCKS		Date MAR 2001
Scale	Drawn	©Copyright Drawing. No part to be copied in any way without prior written consent <b>JOHN SMITH &amp; SONS</b> Midland Clock Works, 112 Alferton Road, Derby DE21 4AU, England	Drawing No. DN233A

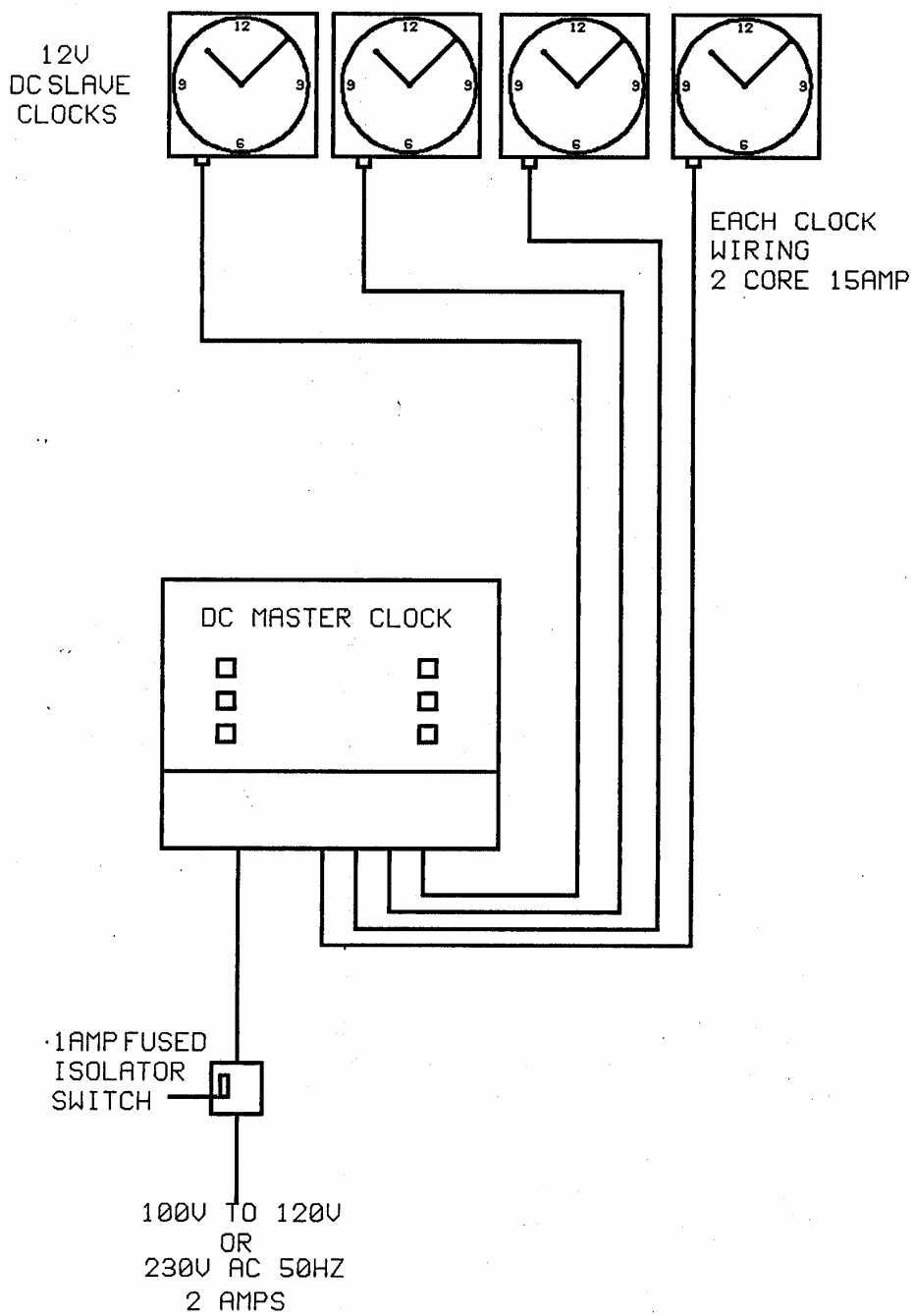

Project No.		Title	Date
		DC MASTER CLOCK AND SLAVE CLOCKS	MAR 2001
Scale	Drawn	©Copyright Drawing. No part to be copied in any way without prior written consent <b>JOHN SMITH &amp; SONS</b> Midland Clock Works, 112 Alferton Road, Derby DE21 4AU, England	Drawing No. DN233